

ULTRA LOW-POWER 32 GBd 2-bit DAC FOR MACH-ZEHNDER MODULATOR

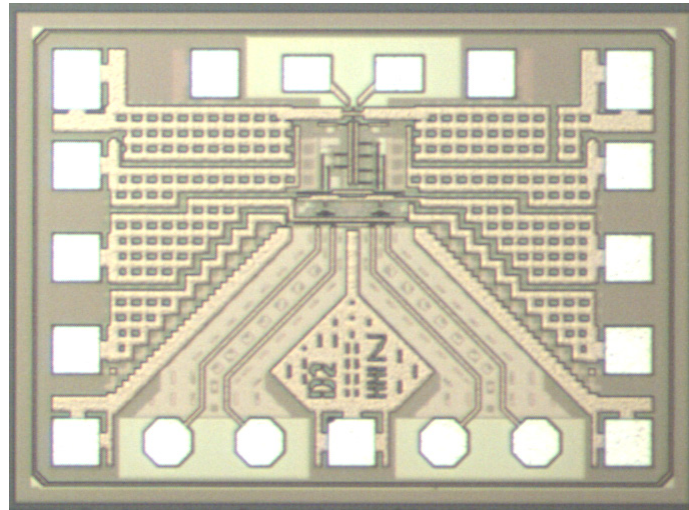

AT A GLANCE

32 GBd 2-bit DAC for Mach-Zehnder Modulator



Features

- Differential inputs and differential output
- Ultra-Low Power, 145 mW
- Eye-level control in PAM-4
- $1.7V_{pp}$, differential output with $2 \times 25 \Omega$ loads
- Supports NRZ, PAM-4 output signals

Applications

- Telecom and Datacom
- Broadband signal amplification
- PAM-4 / NRZ driver for Mach-Zehnder modulator

Ultra low-power 2-bit DAC

Ultra low-power SiGe 2-bit DAC generates either NRZ or PAM-4 electrical signal to driver InP Mach-Zehnder modulator. The output stage is designed to include $2 \times 25 \Omega$ for the impedance matching with the modulator. 2-bit DAC with $2 \times 50 \Omega$ output impedance is also available as laboratory sample upon request.

Specifications

Parameter	Min	Typ	Max	Unit	Conditions
Bandwidth		145		mW	
Data Rate			32	GBd	
Differential Input Signal		500		mV _{pp}	AC-coupled, differential
Differential Output Signal		1700		mV _{pp}	2 x 2,5Ω load, differential
Power Supply		2,2		V	Supply at 25Ω: 2,0V
Operation Temperature		40		°C	

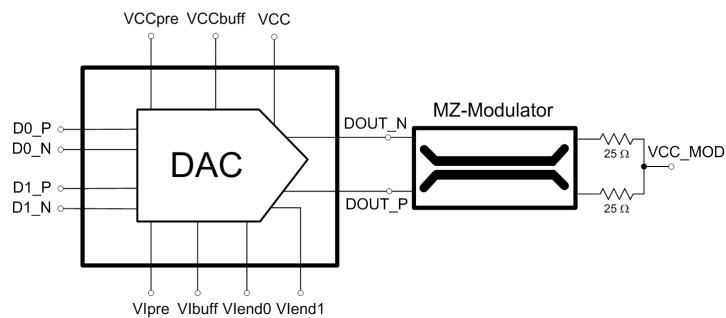

Electrical DAC configuration with Mach-Zehnder Modulator



Dr. Jung Han Choi
 InP and RF

Phone +49 30 31002-471
 jung-han.choi@hhi.fraunhofer.de

Fraunhofer Heinrich Hertz Institute
 Einsteinufer 37, 10587 Berlin
 Germany

www.hhi.fraunhofer.de/pir

Electrical 28 GBd Eye with eye-level control

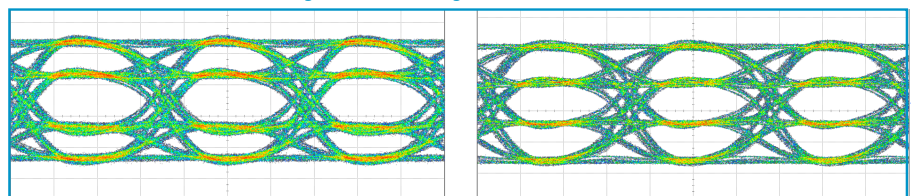

Electro-Optical 28 GBd Eye

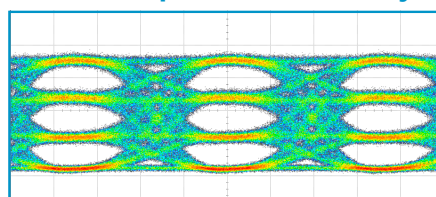

Electro-Optical 32 GBd Eye

